

# esi

## GENSPEC® GD4200-USB Digital Pressure Transmitter

- Pressure ranges from vacuum to 5000 bar
- Sample rate software selection up to 1000 Hz
- Silicon-on-Sapphire pressure sensor technology
- Free ESI-USB® downloadable software with auto update
- Measure & record up to 16 pressure inputs together
- Create customised test certificates
- Automatic temperature compensation
- Support for easy integration with applications created by C#, VB, Labview and Excel VBA (api dll library)
- 2m lead & carry case included



The award winning GD4200-USB digital pressure transmitter is facilitated by the ESI-USB® Windows interface software, giving the user full control of the monitoring, recording, and analysis of pressure data.

The digitally self scaling software provides accurate, high resolution measurement at a precision greater than 1 in 10,000 and is compatible with Windows 8 | 8.1 | 10 | 11.

## Specifications

The GENSPEC Dynamic GD4200-USB digital pressure transmitter offers reliable and accurate pressure measurement from vacuum to 5000 bar. It is specifically designed to measure, analyse, and record pressure directly to your PC without the need of costly I/O interface boards. The easy "plug and play" nature of the unit allows the user to easily download the free ESI-USB© software and view live pressure data in as little as 10 minutes.

The unique Silicon-on-Sapphire sensor technology provides outstanding performance and gives excellent stability over a wide temperature range. Excellent measurement accuracy provides high resolution with a precision greater than 1 in 10,000. Ten pressure ranges have been carefully selected to enable the user to cover any pressure that the application requires, from vacuum up to 5,000 bar, via the use of the ESIUSB© digitally self-scaling software.

Each unit is supplied with 2m USB lead (rated to IP68), and a convenient carry case.

### Typical applications include:

- Test and Measurement
- Laboratory or process measurement
- Leak testing and continuous monitoring

## Dimensions (in mm)

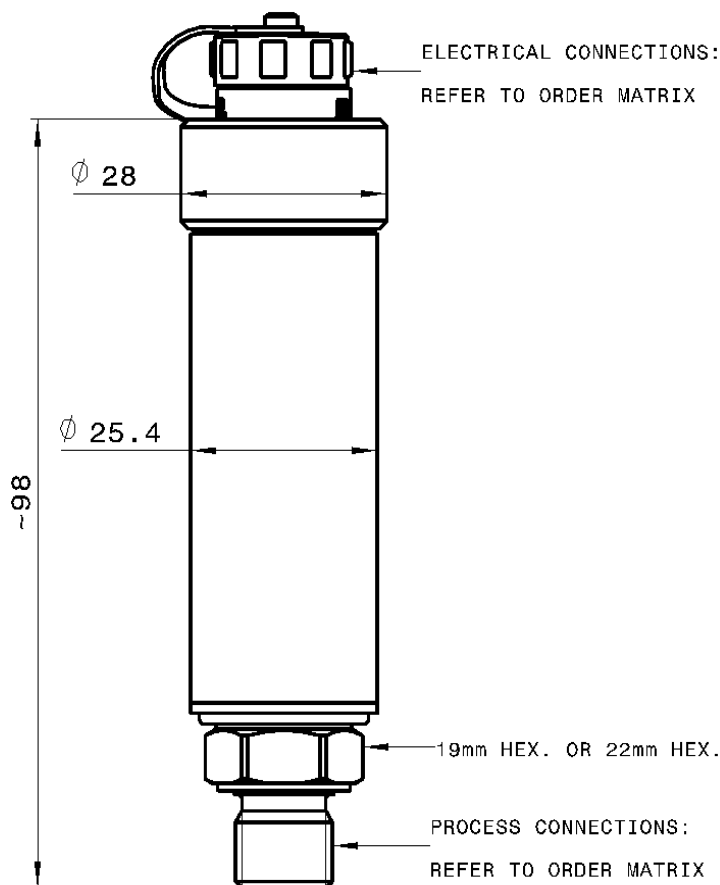

Electrical Connections
USB Mini B Socket
MIL-C-26482 (6-PIN)

Hex Size	Range/Thread
19mm	10 bar and above
22mm	Below 10 bar
	F250-C
25.4mm	M16 HP
	-1 to 2.5 bar SS

## ESI-USB Software

Data is presented on the PC via the ESI-USB® fully configurable Windows Interface software. It has instant connection with auto-detection, and will configure automatically with your desktop, laptop or Windows tablet via USB protocol. The sample rate enables dynamic pressures to be measured with up to 21 bit resolution at user selectable speeds up to 1000 Hz.

For real-time analysis, data transferred to the PC is achieved without loss of accuracy or bandwidth. Compatible with computers with USB 2.0/3.0x type A ports, the ESI-USB® interface configuration and analysis software runs on Windows 8, 8.1, 10 and 11. Data can be displayed in graphical or tabular form, with a choice of pressure units and fully adjustable scales and saved to a file or exported to Excel/PDF/CSV.

The ESI-USB® software has many features including custom certificate generation, customisable certificate templates, leak testing, record and view up to 16 sensors at the same time, virtual differential pressure measurement, set automatic test start and stop times, alarm levels for each individual sensor and excellent measurement accuracy which provides high resolution with a precision greater than 1 in 10000.

It is available to use in 7 languages- English, German, French, Spanish, Italian, Portuguese and Chinese.

We are continually enhancing

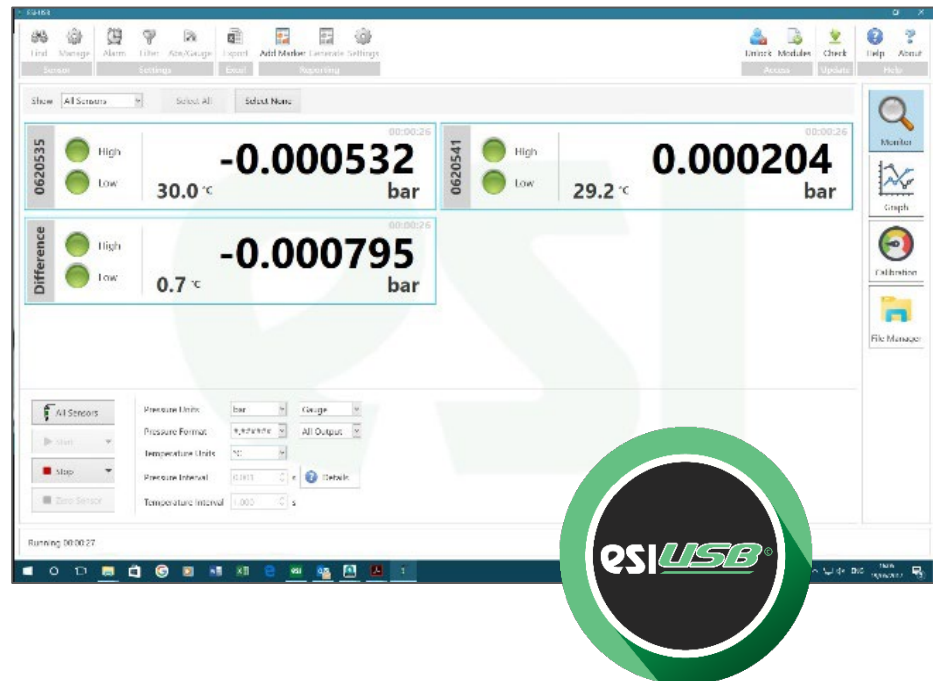

The advanced sensor design consists of a piezoresistive silicon strain gauge circuit, which is epitaxially grown onto the surface of a sapphire diaphragm to form a single crystalline structure. The sapphire sensor element is then molecularly bonded to a titanium alloy sub-diaphragm.

This enables the sensor to endure higher over-pressures and provides superb corrosion resistance. The sensor exhibits virtually no hysteresis and excellent long-term stability over wide temperature ranges.

## Technical Data

Type	GD4200-USB	
Sensor Technology:	Silicon-on-Sapphire (SOS) ; Optional Isolated Piezoresistive Silicon	
Output Signal:	USB 2.0 compatible	
Supply Voltage:	5 Vdc via USB bus	
Pressure Reference:	Gauge (default); Absolute reference input by user	
Standard Pressure Ranges (bar):	-1 to 2.5 bar; 0-16 bar; 0-100 bar; 0-400 bar; 0-1000 bar; 0-1500 bar; 0-2000 bar; 0-3000 bar; 0-4000 bar; 0-5000 bar	
Standard Pressure Ranges (other):	User selectable for psi and other measurement units	
Overpressure Safety:	2x up to 400 bar; 1.5x for 1000 bar; 1.1x for 1500 bar; 1.5x for 2000 bar; 1.25x for 3000+ bar; 1.2x for 5000 bar	
Accuracy NLHR:	Ranges to 3000 bar: $\leq \pm 0.15$ % of span BFSL	Ranges above 3000 bar: $\leq \pm 0.35$ % of span BFSL
Sample Rate:	User selectable to 1000 samples per second (1000 Hz) Resolution: 21 bits for $\leq 5$ Hz; 16 bits for $> 5 - 1000$ Hz	
Operating Ambient Temperature:	-20 °C to +85 °C (-4 °F to +185 °F)	
Operating Media Temperature:	-50 °C to +125 °C (-58 °F to +257 °F)	
Storage Temperature:	+5 °C to +40 °C (+41 °F to +104°F) Recommended Best Practice	
Temperature Effects:	$\pm 1.5\%$ FS total error band for -10°C to +80°C. Typical thermal zero and span coefficients $\pm 0.015$ %FS/°C	
Electromagnetic Compatibility:	EN61326-1, EN61326-2-3 (Laboratory equipment)	
Wetted Parts:	Titanium alloy; Optional stainless-steel 316 (SS) with NBR O-ring for ranges -1 to 2.5 bar only	
Pressure Media:	All fluids compatible with titanium alloy; Optional stainless-steel 316 (SS) for range -1 to 2.5 bar only	
Pressure Connection:	1/4" BSP male (G1/4); 1/4" NPT male, F250-C (Autoclave) or M16 x 1.5 female cone seal	
Electrical Connection:	Standard version supplied with USB mini B to USB A 2m cable Heavy Duty version supplied with MIL-C-26482 (6 PIN) to USB A 2m cable	
Software Compatibility:	Windows 8   8.1   10   11	
Net. Weight (Kg):	0.15 Kg	

## Order Matrix

Output	Type	Options	Pressure Range	Process Connection	Options
Dynamic (1000 Hz)	GD4200				
<b>Electrical Connections/Options</b>					
USB Mini B		-USB			
MIL-C-26482 (6 PIN)		BUSB			
<b>Pressure Range</b>					
-1 to 2.5 bar			02.5		
0-16 bar			0016		
0-100 bar			0100		
0-400 bar			0400		
0-1000 bar			1000		
0-1500 bar			1500		
0-2000 bar			2000		
0-3000 bar			3000		
0-4000 bar			4000		
0-5000 bar			5000		
<b>Process Connection</b>					
1/4" BSP male (G1/4)				AB	
1/4" NPT male				AM	
Autoclave F250-C female (for pressures above 1500 bar)				DE	
M16 x 1.5 female cone seal				FK	
<b>Options</b>					
Stainless-steel (SS) sensor (-1 to 2.5bar)					-SS

### Order Number Example

GD4200-USB1500AB

For options not listed please contact the sales team

**DISCLAIMER:** ESI Technology Ltd operates a policy of continuous product development. We reserve the right to change specification without prior notice. All products manufactured by ESI Technology Ltd are calibrated using precision calibration equipment, traceable to national measurement standards.