

# esi

## ADHT

### High Temperature Adapter

- For use with media up to 200°C
- Effectively reduces the temperature of the media before coming in to contact with the transmitter
- Safe to use with pressures up to 400 bar
- For use with steam or hot gases
- A range of process connections available
- Great chemical compatibility



## Specifications

The ADHT Cooling Coil Adapter provides thermal isolation for a pressure transducer from hot liquid or gas media. It is an ideal solution for applications where the media temperature exceeds the rating of a pressure transducer or transmitter.

The Cooling Coil adapter will effectively reduce the temperature of the media, depending on the ambient temperature, before it makes contact with the transducer sensing element. The ADHT can be used with media up to 200°C and with pressure ranges up to 400 bar max.

Constructed entirely from 316L stainless steel, it offers a simple yet effective solution to high temperature applications when used with ESI pressure sensors.

## Dimensions (in mm)

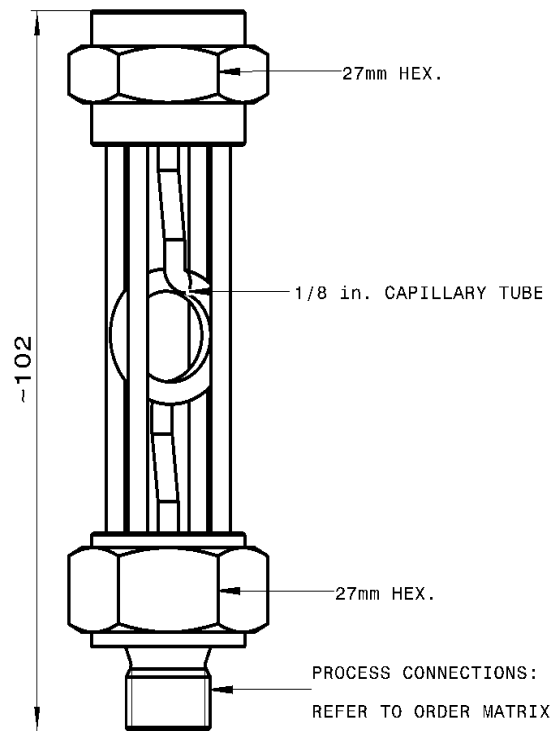

## Order Matrix

| Type       | Connection to Transmitter | Process Connection               |
|------------|---------------------------|----------------------------------|
| ADHT25     | 1/4" BSP female           | 1/4" BSP male (G1/4) (DIN3852-A) |
| ADHT50     | 1/4" BSP female           | 1/2" BSP male (G1/2)             |
| ADHT25/NPT | 1/4" NPT female           | 1/4" NPT male                    |